

40th International Chemistry Olympiad

Practical tasks

15 July 2008
Budapest, Hungary

Instructions

- This examination has **10 pages** and **5 pages** of answer sheets (8+4 for Task 1-2, 2+1 for Task 3).
- You have **3 hours** to complete **Tasks 1 and 2**. After that you will have to leave the laboratory for a short **break** while the assistants exchange your glassware and chemicals. You will then have **2 hours** to work on **Task 3**.
- Begin only when the **START** command is given. You must stop your work immediately when the **STOP** command is given after each part. A delay in doing this by 3 minutes will lead to cancellation of your experimental exam.
- Follow **safety rules** given in the IChO regulations. At all times while you are in the laboratory you must wear **safety glasses** or your own glasses if they have been approved, and use the **pipette filler bulb** provided. Use **gloves** when handling the organic liquids.
- You will receive only **ONE WARNING** from the laboratory supervisor if you break safety rules. On the second occasion you will be dismissed from the laboratory with a resultant zero score for the entire experimental examination.
- Do not hesitate to ask a demonstrator if you have any questions concerning safety issues or if you need to leave the room.
- Use only the pen and calculator provided.
- Write your **name and code on each answer sheet**. Do not attempt to separate the sheets.
- All results must be written in the appropriate areas on the answer sheets. Anything written elsewhere will not be graded. Use the reverse of the sheets if you need scratch paper.
- You will need to reuse some glassware during the exam. Clean them carefully at the sink closest to you.
- Use the labeled **waste containers** under the hood for the disposal of organic liquids from Task 1 and all liquids from Task 3.
- The number of **significant figures** in numerical answers must conform to the rules of evaluation of experimental errors. Mistakes will result in penalty points, even if your experimental technique is flawless.
- Chemicals and laboratory ware are not supposed to be **refilled or replaced**. Each such incident (**except the first**) will result in the **loss of 1 point** from your 40 practical points.
- When you have finished a part of the examination, you must put your answer sheets into the envelope provided. Do not seal the envelope.
- The official English version of this examination is available on request only for clarification.

Apparatus

For common use in the lab:
Heating block preadjusted to 70 °C under the hood
Distilled water (H ₂ O) in jugs for refill
Latex gloves (ask for a replacement if allergic to latex)
Labeled waste containers for Task 1 (organic liquids) and Task 3 (all liquids)
Container for broken glass and capillaries
On each desk:
Goggles
Heat gun
Permanent marker
Pencil and ruler
Stopwatch, ask supervisor about operation if needed. (You can keep it.)
Tweezers
Spatula
Glass rod
Ceramic tile
Paper tissue
Spray bottle with distilled water
9 Eppendorf vials in a foam stand
TLC plate in labeled ziplock bag
Plastic syringe (100 mL) with polypropylene filter disc
Pipette bulb
14 graduated plastic Pasteur pipettes (droppers)
Petri dish with etched competitor code
Burette
Stand and clamp
Pipette (10 mL)
2 beakers (400 mL)
Beaker and watchglass lid with filter paper piece for TLC
10 capillaries
2 graduated cylinders (25 mL)
3 Erlenmeyer flasks (200 mL)
Beaker (250 mL)
2 beakers (100 mL)
Funnel
Volumetric flask (100 mL)
30 test tubes in stand*
Indicator paper pieces and pH scale in ziplock bag*
Wooden test tube clamp*
2 plugs for test tubes*

* Only handed out for Task 3

Chemicals

Sets for 4-6 people	R phrases	S phrases
0.025 mol/dm ³ ferriin solution	52/53	
0.2 % diphenylamine, (C ₆ H ₅) ₂ NH solution in conc. H ₂ SO ₄	23/24/25-33-35-50/53	26-30-36/37-45-60-61
0.1 mol/dm ³ K ₃ [Fe(CN) ₆] solution	32	
Pumice stone		
On each desk:		
50 mg anhydrous ZnCl ₂ in a small test tube (in the foam stand, labeled with code)	22-34-50/53	36/37/39-26-45-60-61
100 mg β-D-glucopyranose pentaacetate (labelled as BPAG)		
3.00 g anhydrous glucose, C ₆ H ₁₂ O ₆ , preweighed in vial		
(CH ₃ CO) ₂ O in Erlenmeyer flask (12 mL)	10-20/22-34	26-36/37/39-45
(CH ₃ CO) ₂ O in vial (10 mL)	10-20/22-34	26-36/37/39-45
CH ₃ COOH in vial (15 mL)	10-35	23-26-45
CH ₃ OH in vial (10 mL)	11-23/24/25-39	7-16-36/37-45
30 % HClO ₄ in CH ₃ COOH in vial (1 mL)	10-35	26-36/37/39-45
1:1 isobutyl acetate – isoamyl acetate in vial (20 mL), labeled as ELUENT	11-66	16-23-25-33
solid K ₄ [Fe(CN) ₆].3H ₂ O sample with code in small flask	32	22-24/25
ZnSO ₄ solution labeled with code and concentration (200 mL)	52/53	61
0.05136 mol/dm ³ Ce ⁴⁺ solution (80 mL)	36/38	26-36
1.0 mol/dm ³ H ₂ SO ₄ solution (200 mL)	35	26-30-45
Sample solutions for Task 3 (to be handed out at the start of Task 3)	1-26/27/28-32-35-50/53	24/25-36/39-61

Risk and Safety Phrases

Indication of Particular Risks			
1	Explosive when dry	33	Danger of cumulative effects
10	Flammable	34	Causes burns
11	Highly Flammable	35	Causes severe burns
22	Harmful if swallowed	39	Danger of very serious irreversible effects
32	Contact with concentrated acids liberates very toxic gas		
Combination of Particular Risks			
20/22	Harmful by inhalation and if swallowed	36/38	Irritating to eyes and skin
23/24/25	Toxic by inhalation, in contact with skin and if swallowed	50/53	Very toxic to aquatic organisms, may cause long-term adverse effects in the aquatic environment
26/27/28	Very Toxic by inhalation, in contact with skin and if swallowed	52/53	Harmful to aquatic organisms, may cause long-term adverse effects in the aquatic environment
Indication of Safety Precautions			
7	Keep container tightly closed	30	Never add water to this product
16	Keep away from sources of ignition - No smoking	33	Take precautionary measures against static discharges
22	Do not breathe dust	36	Wear suitable protective clothing
23	Do not breathe fumes/vapour	45	In case of accident or if you feel unwell, seek medical advice immediately (show label where possible)
25	Avoid contact with eyes	60	This material and/or its container must be disposed of as hazardous waste
26	In case of contact with eyes, rinse immediately with plenty of water and seek medical advice	61	Avoid release to the environment.
Combination of Safety Precautions			
24/25	Avoid contact with skin and eyes	36/37/39	Wear suitable protective clothing, gloves and eye/face protection
36/37	Wear suitable protective clothing and gloves		

Task 1

Synthesis of α -D-glucopyranose pentaacetate

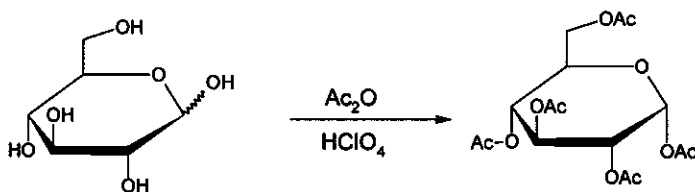

Caution: Use gloves while handling acetic acid and acetic anhydride. Let the lab supervisors know if any is spilled.

Add 12 mL of pure acetic acid to the 12 mL of acetic anhydride provided in an Erlenmeyer flask and mix well (acetic anhydride is used in excess). Add the entire 3.00 g glucose to the flask. Add 5 drops of 30% HClO_4 dissolved in acetic acid using a Pasteur-pipette. **After the addition of the catalyst, the solution might warm up considerably.**

Cover the mixture with a watchglass and keep it for 10 minutes, with occasional swirling. Pour the reaction mixture into 100 mL of distilled water in a beaker. Scratch the walls of the beaker with a glass rod to initiate crystallization, leave the flask for crystallization for 10 minutes. Filter and wash the product two times with 10 mL of water using the syringe and the porous polypropylene filter disc fitted in the syringe.

Filtration using a plastic syringe

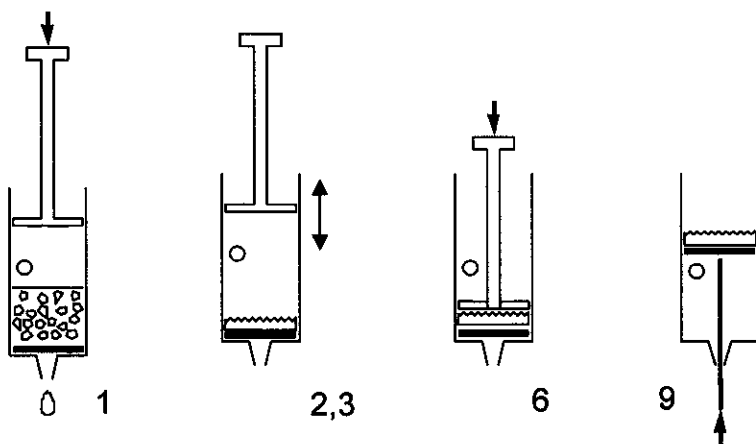

1. Pull out the piston. Fill the syringe from above with the above product suspension to be filtered. The syringe can be filled to the level of the hole. Replace piston. (refer to figure no. 1)
2. Cover the hole with your finger and press the piston slowly upto the hole.
3. Remove your finger and draw the piston back. Do not draw in air through the filter.
4. Repeat steps 2-3 a few times to remove the liquid from the product. (refer to figure no. 2,3)
5. Repeat steps 1-4 until all solids are on the filter.
6. Press the piston against the filter cake and squeeze out any remaining liquid. (refer to figure no. 6)
7. Wash the product twice with 10 mL of water repeating steps 1-4.

8. Press the piston against the filter cake and squeeze out remaining water.
 9. Pull the piston out with the hole closed to lift out the filter cake. Use spatula to push if required as shown above in figure no.9.
- a) Place your product in the open Petri dish marked with your code. Leave it on your table. The organizers will dry it, weigh it and check it for purity.
 - b) Calculate the theoretical yield (mass) of your product in g. ($M(C) = 12 \text{ g/mol}$, $M(O) = 16 \text{ g/mol}$, $M(H) = 1.0 \text{ g/mol}$)

Synthesis of α -D-glucopyranose pentaacetate from β -D-glucopyranose pentaacetate

An alternative synthesis of α -D-glucopyranose pentaacetate starts from readily available β -D-glucopyranose pentaacetate. In this experiment we will study the kinetics of this reaction with thin layer chromatography.

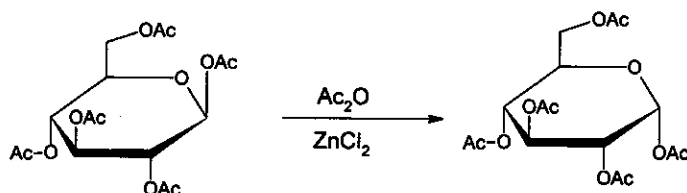

Take 1.5 mL acetic anhydride (from the given vial) and add it to 50 mg of anhydrous ZnCl_2 (supplied in a preweighed test tube). Add the entire 100 mg of pure β -D-glucopyranose pentaacetate (BPAG) and swirl until dissolved. Take three drops from this mixture into an Eppendorf tube, add 0.5 mL methanol and keep it aside.

Place the test tube in the heating apparatus preadjusted to 70°C kept in the hood closest to your desk (mark your code before putting it). Mix the contents of the test tube from time to time. During the reaction, take three drops of sample from the mixture with a Pasteur pipet after 2, 5, 10, and 30 minutes (use stopwatch) in an Eppendorf tube. Add 0.5 mL of methanol immediately to each sample to stop the reaction.

Prepare a silica TLC plate with the collected samples to study the reaction kinetics. Apply the necessary reference compounds to help identification of the spots on the plate. Mark the spots with a pencil, and develop the plate in isobutyl acetate/ isoamyl acetate (1:1) eluent. Heat the plates with a heat-gun (under the hood!) to visualise the spots (the colour is stable). You can ask for a second plate **without penalty points**, if needed.

- c) Sketch your developed TLC plate and place your plate in the labeled ziplock bag and leave it on your desk for evaluation.
- d) Interpret your experimental findings by answering the questions on the answer sheet.

Task 2

When potassium hexacyanoferrate(II), $K_4[Fe(CN)_6]$ is added to a solution containing zinc ions, an insoluble precipitate forms immediately. Your task is to find out the composition of the stoichiometric precipitate that contains no water of crystallization.

The precipitation reaction is quantitative and so quick that it can be used in a titration. The end point can be detected using redox indication, but first the concentration of the potassium hexacyanoferrate(II) solution has to be determined.

Preparation of $K_4[Fe(CN)_6]$ solution and determination of its exact concentration

Dissolve the solid $K_4[Fe(CN)_6] \cdot 3H_2O$ ($M = 422.41$ g/mol) sample in the small Erlenmeyer flask using distilled water and quantitatively transfer it into the 100 mL volumetric flask.

Pipette out 10 mL of the hexacyanoferrate(II) sample solution.

Hint: The pipette has two graduation marks. Volume between the two marks is to be used. Do not let all the solution to run out in the flask.

Add 20 mL sulfuric acid (1 mol/dm³) and two drops of the ferroin indicator solution to each sample before titration. Titrate with the 0.05136 mol/dm³ Ce^{4+} solution.

Repeat titration as necessary.

Cerium(IV) is a strong oxidant under acidic conditions forming Ce(III).

- Report the Ce^{4+} solution volumes consumed.
- Write the equation for the titration reaction. What was the mass of your $K_4[Fe(CN)_6] \cdot 3H_2O$ sample?

The reaction between zinc ions and potassium hexacyanoferrate(II)

Take 10 mL of the hexacyanoferrate(II) sample solution and add 20 mL of sulfuric acid (1 mol/dm³). Add three drops of indicator solution (diphenyl amine) and two drops of $K_3[Fe(CN)_6]$ solution.

The indicator only works if the sample contains some hexacyanoferrate(III), $[Fe(CN)_6]^{3-}$. Titrate slowly with the zinc solution. Continue until a bluish violet colour appears. Repeat titration as necessary.

- Report the zinc solution volumes consumed.
- Interpret the titration by answering the questions on the answer sheet.
- Determine the formula of the precipitate.

Caution: Best marks are not necessarily awarded to measurements reproducing theoretically expected values.

Task 3

Caution: Handle all unknown solutions as if they were toxic and corrosive. Discard them only in the appropriate waste container.

The heat gun heats the expelled air up to 500 °C. Do not direct the stream towards combustible materials or body parts. Be careful with the hot nozzle.

Always place a single piece of pumice into liquids before heating to avoid bumping. Never point the mouth of a heated test tube towards a person.

You have eight unknown aqueous solutions. Each solution contains only one compound. The same ion may appear in more than one solution. Every compound formally consists of one type of cation and one type of anion from the following list:

Cations: H^+ , NH_4^+ , Li^+ , Na^+ , Mg^{2+} , Al^{3+} , K^+ , Ca^{2+} , Cr^{3+} , Mn^{2+} , Fe^{2+} , Fe^{3+} , Co^{2+} , Ni^{2+} , Cu^{2+} , Zn^{2+} , Sr^{2+} , Ag^+ , Sn^{2+} , Sn^{4+} , Sb^{3+} , Ba^{2+} , Pb^{2+} , Bi^{3+}

Anions: OH^- , CO_3^{2-} , HCO_3^- , CH_3COO^- , $\text{C}_2\text{O}_4^{2-}$, NO_2^- , NO_3^- , F^- , PO_4^{3-} , HPO_4^{2-} , H_2PO_4^- , SO_4^{2-} , HSO_4^- , S^{2-} , HS^- , Cl^- , ClO_4^- , MnO_4^- , Br^- , I^-

You have test tubes and heating gun but no additional reagents apart from distilled water and pH paper.

Identify the compounds in the solutions 1-8. You can use the solubility table for some of the anions on the next page. If you are unable to identify an ion exactly, give the narrowest selection possible.

Remarks:

The unknown solutions may contain minor impurities arising from their exposure to air. The concentration of all solutions is around 5 % by mass, so you can expect clearly observable precipitates from the main components. In some cases, precipitation does not occur instantaneously; some substances may remain in an oversaturated solution for a while. Don't draw negative conclusions too hastily, wait 1-2 minutes where necessary. Always look carefully for all signs of a reaction.

Keep in mind that heating accelerates all processes, increases the solubility of most substances, and may start reactions that do not take place at room temperature.

Solubility Table at 25 °C

	NH ₄ ⁺	Li ⁺	Na ⁺	Mg ²⁺	Al ³⁺	K ⁺	Ca ²⁺	Cr ³⁺	Mn ²⁺	Fe ²⁺	Fe ³⁺	Co ²⁺	Ni ²⁺	Cu ²⁺	Zn ²⁺	Sr ²⁺	Ag ⁺	Sn ²⁺	Sn ⁴⁺	Sb ³⁺	Ba ²⁺	Pb ²⁺	Bi ³⁺	
CH ₃ COO ⁻														HR			1.0	↓	↓	↓				↓
C ₂ O ₄ ²⁻			3.6	↓					↓	↓ (Y)	↓	↓	↓	↓	↓	↓	↓	↓	↓	↓	↓	↓	↓	↓
NO ₂ ⁻	HR				HR					↓ R				HR	↓		0.41 (Y)	↓ R	↓	↓				↓
NO ₃ ⁻																								
F ⁻		0.13		↓	0.5		↓	4.0	1.0	↓ (W)	↓ (W)	1.4	2.6	↓	1.6	↓			↓		0.16	↓	↓	↓
SO ₄ ²⁻							0.21										0.84		↓		↓	↓	↓	↓
PO ₄ ³⁻	HR	↓		↓	↓		↓	↓	↓	↓ (W)	↓	↓ (P)	↓	↓	↓	↓	↓ (Y)	↓	↓	↓	↓	↓	↓	↓
HPO ₄ ²⁻		↓		↓	↓		↓	↓	↓	↓ (W)	↓ (W)	↓ (P)	↓	↓	↓	↓	↓ (Y)	↓	↓	↓	↓	↓	↓	↓
H ₂ PO ₄ ⁻					HR		1.0	HR	HR		↓ (W)	HR		↓	↓	HR	↓ (Y)	↓	↓	↓	HR	↓	↓	↓
ClO ₄ ⁻						2.1																		
MnO ₄ ⁻	HR							HR	↓ R	R		HR					0.91	R		R		↓ R		
Br ⁻																	↓ (Y)					0.98		
I ⁻											R			↓ R			↓ (Y)	1.0				↓ (Y)	↓ (B)	↓ (B)

No entry: Soluble compound ↓: Insoluble compound R: Redox reaction at room temperature
HR: Soluble at room temperature. In hot solution a reaction with an observable effect (not necessarily a precipitate) takes place.
 Solubilities in g (substance) / 100 g water. Accurately known values between 0.1 and 4 are shown only.
 Precipitates whose colour significantly differs from that of their hydrated ions: **(B)** = black, **(P)** = purple, **(W)** = white, **(Y)** = pale yellow, **(Y)** = yellow.

Name:

Code: IND-

Task 1

10% of the total

1a	1b	1c	1d	Task 1
30	2	12	4	48

a) Yield of the product in g, measured by the organizer:

b) Calculate the theoretical yield of your product in g.

Theoretical yield:

c) Sketch your developed TLC plate and place your plate in the labeled ziplock bag and leave it on your desk to be evaluated.

Name:

Code: IND-

d) **Interpret your experiment** and choose the correct answer.

The acetylation reaction of glucose is exothermic.

- a) Yes
- b) No
- c) Cannot be decided based on these experiments

The isomerisation reaction of β -D-glucopyranose pentaacetate can be used for the preparation of pure α -D-glucopyranose pentaacetate.

- a) Yes
- b) No
- c) Cannot be decided based on these experiments

Name:

Code: IND-

Task 2

15 % of the total

2a	2b	2c	2d	2e	Task 2
25	4	25	6	5	65

a) Ce^{4+} titre value:

Average volume consumed (V_1):

b) The titration reaction:

Calculation of sample mass:

$\text{K}_4[\text{Fe}(\text{CN})_6] \cdot 3\text{H}_2\text{O}$ mass (m):

c) Zinc titre value:

Average volume consumed (V_2):

d) Mark the correct answer.

The diphenyl amine indicator changes in colour at the end point

- a) because the concentration of the Zn^{2+} ions increases.
 b) because the concentration of the $[\text{Fe}(\text{CN})_6]^{4-}$ ions decreases.
 c) because the concentration of the $[\text{Fe}(\text{CN})_6]^{3-}$ ions increases.
 d) because the indicator is liberated from its complex.

Name:

Code: IND-

Which form of the indicator is present before the end point?

- a) Oxidized
 b) Reduced
 c) Complexed to a metal ion

At the beginning of the titration the redox potential for the hexacyanoferrate(II) - hexacyanoferrate(III) system is lower than the redox potential of the diphenyl amine indicator.

- a) True
 b) False

e) Determine the formula of the precipitate. Show your calculations.

The formula of the precipitate:

Items replaced or refilled:

Student signature:

Supervisor signature:

Name:

Code: IND-

Task 3

15 % of the total

Task 3
108

Only fill out this table when you are ready with all your assignments.

	1	2	3	4	5	6	7	8
Cation								
Anion								